



NOLEGGIO E VENDITA PONTI E PIATTAFORME AEREE

MONOFASE/TRIFASE PORTATA 1000 KG.



MOD. F 1000 K

PIATTAFORMA DI TRASPORTO PERSONE E MATERIALI





F1000 K

PORTATA MAX
1000 KG.

CONFIGURAZIONE. P1

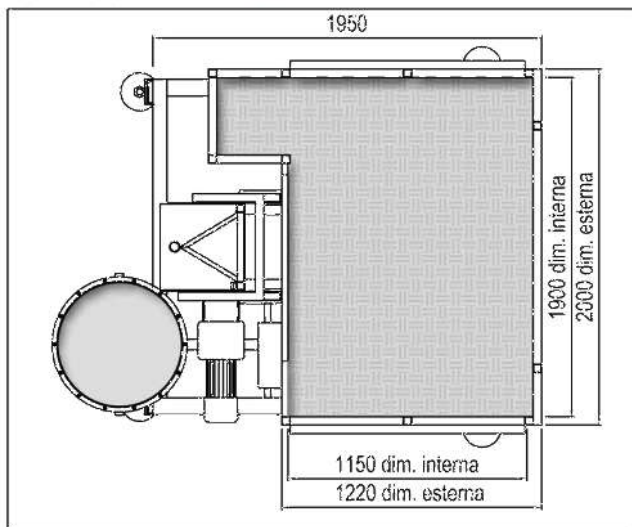

**scegli la tua
configurazione!**

CONFIGURAZIONE. P2

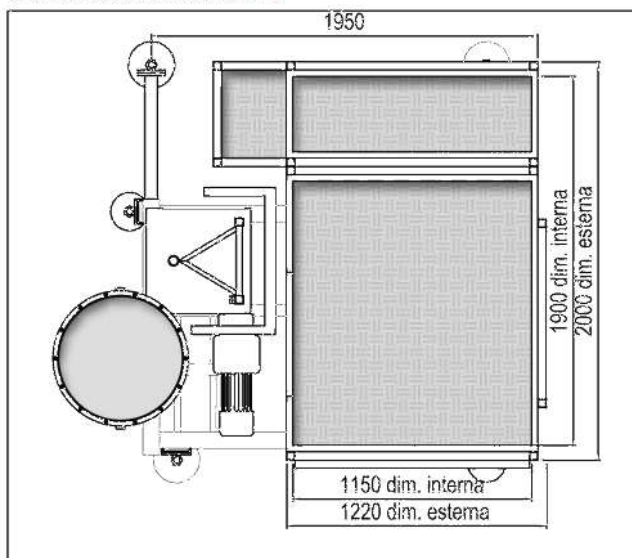

CONFIGURAZIONE. P2

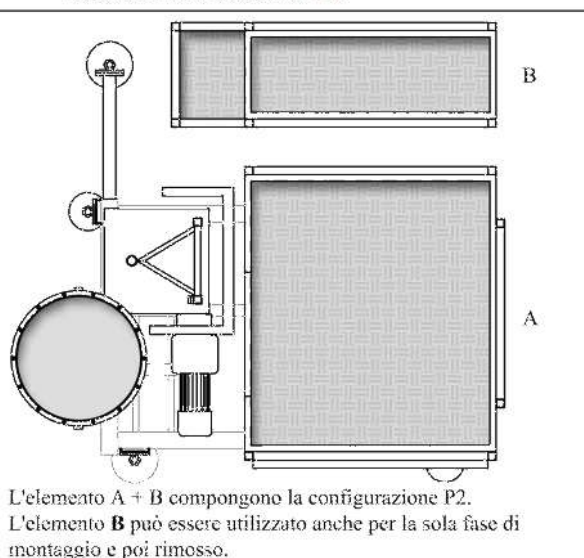

L'elemento A + B compongono la configurazione P2.
L'elemento B può essere utilizzato anche per la sola fase di montaggio e poi rimosso.

CONFIGURAZIONE. P3

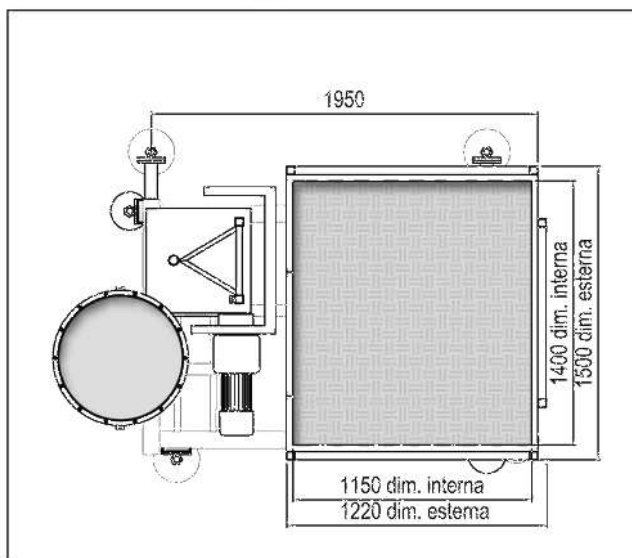

CONFIGURAZIONE. P3

(kit opzionale ribaltina di solo montaggio)

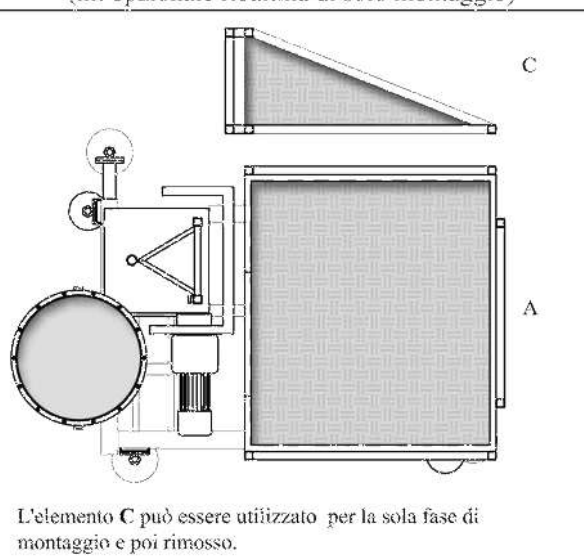

L'elemento C può essere utilizzato per la sola fase di montaggio e poi rimosso.





F1000 K

PORTATA MAX
1000 KG.

PROCEDURA DI SBARCO

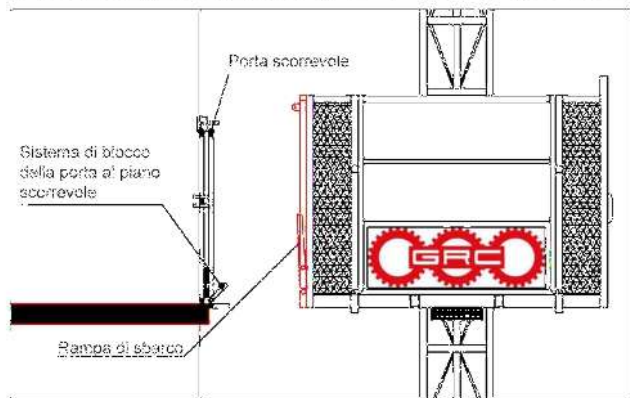

1. Pattino di fermata al piano precedentemente posizionato e regolato per la giusta misura per lo sbarco.

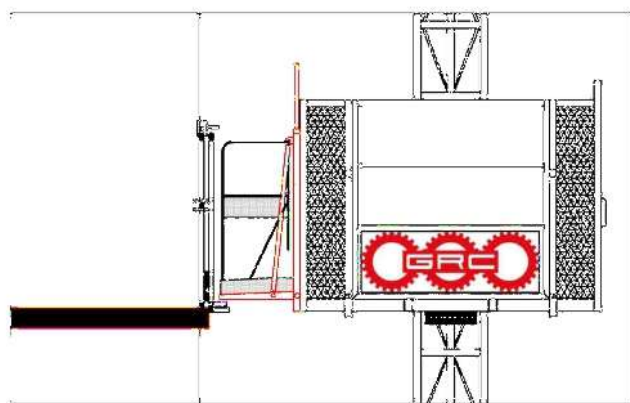

2. Aprire la rampa di sbarco per sbloccare il sistema di apertura della porta al piano scorrevole

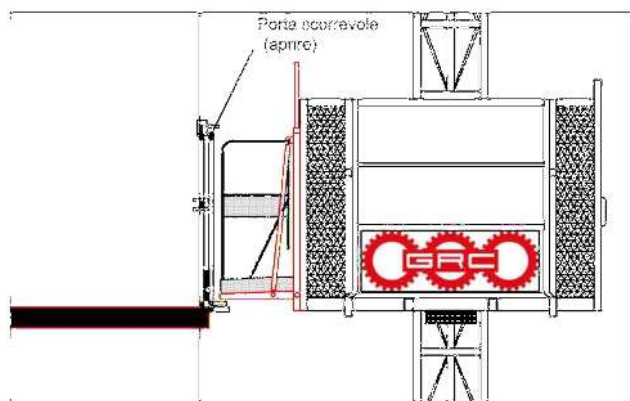

3. Aprire la porta al piano scorrevole per l'accesso ai piani

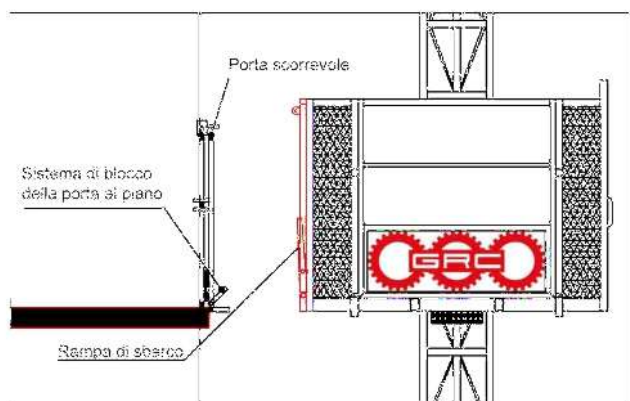

La procedura va ripetuta all'inverso con percorso obbligatorio. Attenzione, prima di chiudere la rampa di sbarco, chiudere la porta scorrevole (fase obbligatoria dato che in caso contrario la rampa di sbarco resta prigioniera e non può essere chiusa).





F1000 K

PORTATA MAX 1000 KG.

DATI TECNICI

Tabella di carico dell' F1000 K per config. P1 / P2

VERSIONE MONOFASE				VERSIONE TRIFASE			
Persone	+	Materiali (kg)	Tot. kg	Persone	+	Materiali (kg)	Tot. kg
1	+	700 kg.	800 kg.	1	+	900 kg.	1000 kg.
2	+	600 kg.	800 kg.	2	+	800 kg.	1000 kg.
3	+	500 kg.	800 kg.	3	+	700 kg.	1000 kg.
4	+	400 kg.	800 kg.	4	+	600 kg.	1000 kg.
5	+	300 kg.	800 kg.	5	+	500 kg.	1000 kg.

Persone max n. 5

Carico max kg. 800

Persone max n. 5

Carico max kg. 1000

Tabella di carico dell' F1000 K per config. P3

N.B: = 100 kg.

VERSIONE MONOFASE				VERSIONE TRIFASE			
Persone	+	Materiali (kg)	Tot. kg	Persone	+	Materiali (kg)	Tot. kg
1	+	900 kg.	1000 kg.	1	+	900 kg.	1000 kg.
2	+	800 kg.	1000 kg.	2	+	800 kg.	1000 kg.
3	+	700 kg.	1000 kg.	3	+	700 kg.	1000 kg.
4	+	600 kg.	1000 kg.	4	+	600 kg.	1000 kg.

Persone max n. 4

Carico max kg. 1000

Persone max n. 4

Carico max kg. 1000



FRENO A PARACADUTE



POSSIBILITÀ
DI ASPORTARE
IL CESTO
AVVOLGICAVO
CON ESTREMA
SEMPLICITÀ PER
LA MESSA IN
FUORI SERVIZIO

	VERSIONE MONOFASE Config. P1/P2	VERSIONE MONOFASE Config. P3	VERSIONE TRIFASE Config. P1/P2	VERSIONE TRIFASE Config. P3
Portata Max kg	800 <small>(comprese le persone)</small>	1000 <small>(comprese le persone)</small>	1000 <small>(comprese le persone)</small>	1000 <small>(comprese le persone)</small>
Velocità di spostamento verticale max.	12 mt/min.	12 mt/min.	12 mt/min.	12 mt/min.
Persone Ammesse Max	5	4	5	4
Dimensione esterna cesta mm.	2000 x 1220	1500 x 1220	2000 x 1220	1500 x 1220
Dimensione ascensore ingombro a terra mm.	2000 x 2250	1500 x 1220	2000 x 2250	1500 x 1220
Dimensione ascensore per il trasporto mm.	2000 x 1950	1500 x 1950	2000 x 1950	1500 x 1950
Altezza Max	100 mt	100 mt	100 mt	100 mt
Intervallo Max tra gli Ancoraggi	7 mt	7 mt	7 mt	7 mt
Alimentazione elettrica Monofase/Trifase	230V 50/60 Hz	230V 50/60 Hz	400V 50/60 Hz	400V 50/60 Hz
Freni Elettromeccanici	1	1	1	1
Freno paracadute	1	1	1	1
Potenza Motore	3 kw	3 kw	4 kw 5.5 kw	4 kw 5.5 kw
Traliccio triangolare H mm.	1500	1500	1500	1500



inserire sempre tutti i perni
per un totale di n.3

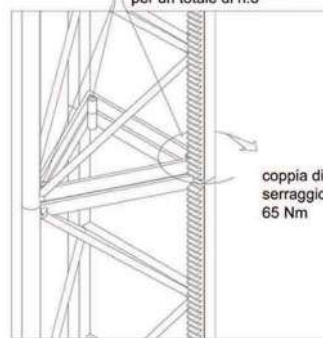

coppia di serraggio
65 Nm

vista prospettica fissaggio traliccio-traliccio

